

1 DETAIL  
E3 (REF:A/S2.2JF)

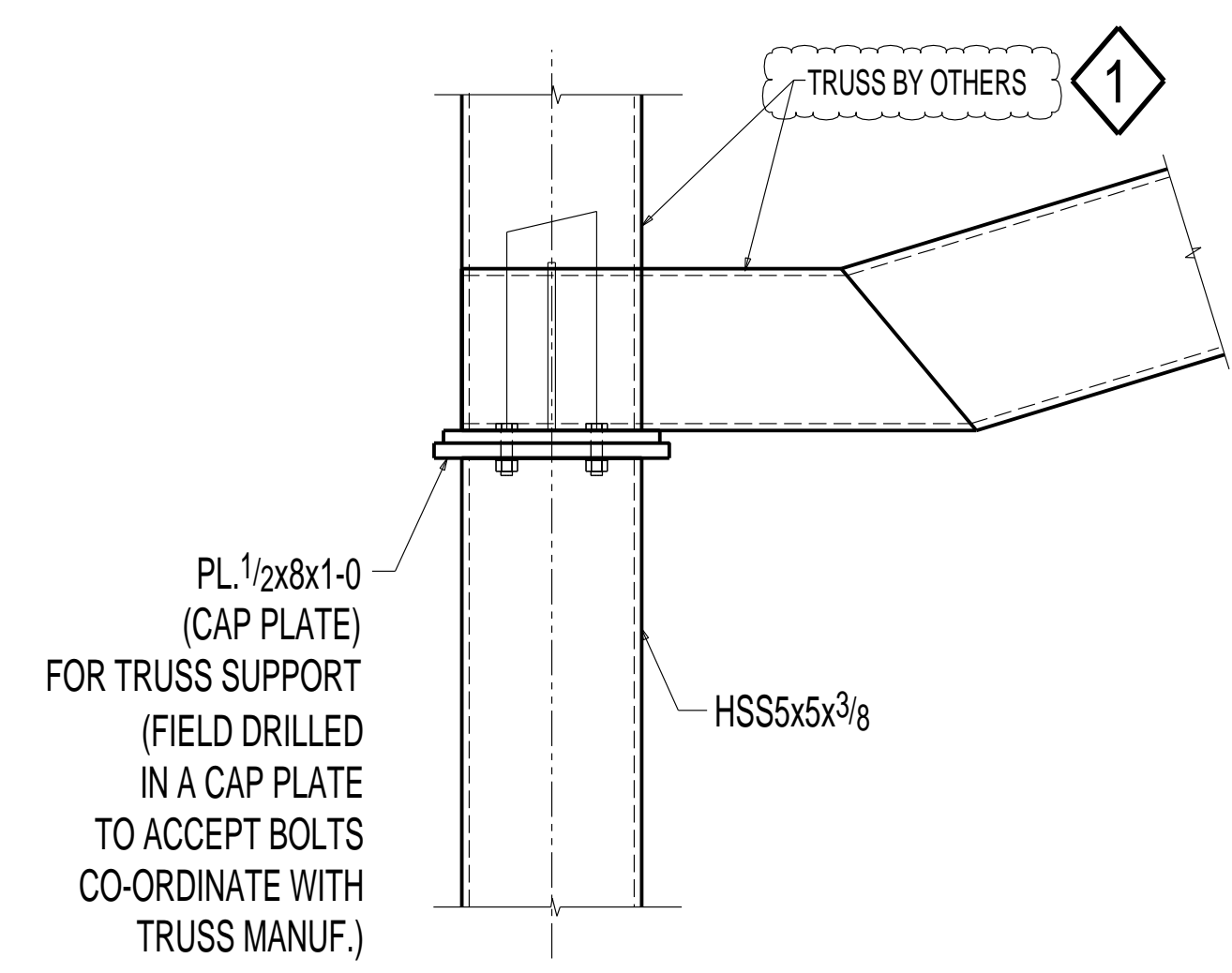

2 DETAIL  
E3 (REF:B/S2.2JF)

- 1 G.C TO CO-ORDINATE ALL LOCATING DIMENSION, ELEVATION, PROFILE SIZE, JOB NORTH BEFORE FABRICATION/ERECTION
- 2 ENTIRE TRUSS SYSTEM IS DESIGNED AND SUPPLIED BY TRUSS MANUFACTURER. AND IT'S CONNECTION WITH STEEL IS CO-ORDINATED WITH G.C BEFORE FABRICATION/ERECTION.